

# Linked, self-steering logistics based on CPS

**Dipl.-Wirtsch.-Ing.  
Julian Popp,**  
Institute of Mechanical  
Handling and Logistics,  
University of Stuttgart



## Automotive production changed (regarding product variation) over the last 40 years



1970



2010



## Material provision 20 years ago



Quelle: Porsche 1992



## Material provision today using logistic supermarkets





## Tugger trains connecting supermarkets and assembly



Lack of flexibility regarding routes!



## Problem analysis for today's premium automotive production

- Further rise in number of variants
- Expensive rework and little flexibility because of fixed conveyor lines
- Logistics need higher amount of space at the assembly lines

→ Logistics costs rising continuously



Image source: Mercedes-Benz

2013 Mercedes A-class (W 176):

138 recommended paint & upholstery combinations

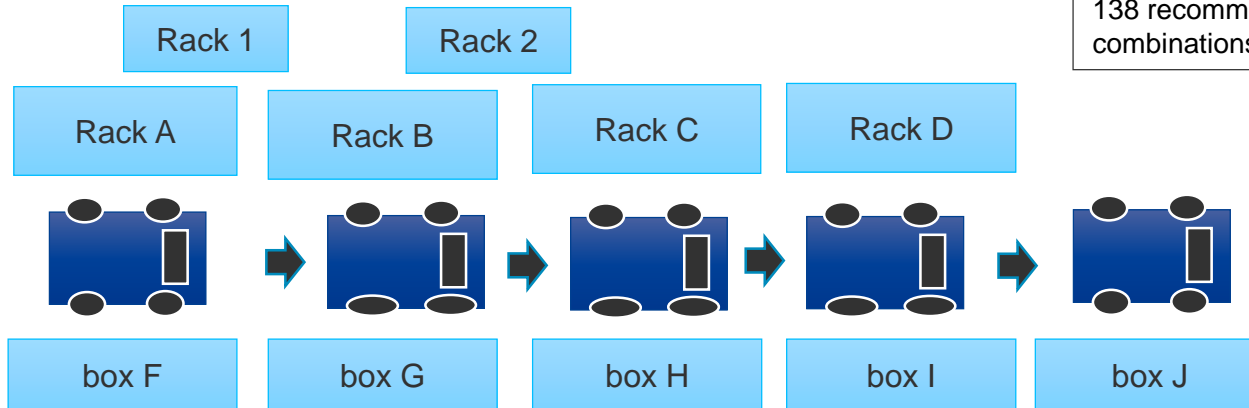



## ARENA2036

Active Research Environment for the Next Generation of Automobiles

- 7500 m<sup>2</sup> testing hall in Stuttgart
- Flexibility and transformation ability
- Human machine interaction
- Partners: Daimler, Bosch, BASF, Faro, Kuka, Bär, Fraunhofer (IAO, IPA) and 6 Institutes of the University of Stuttgart

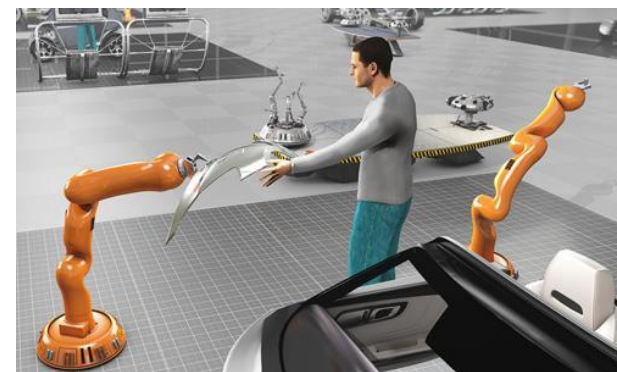



## Innovative worker platform (AGV) to replace conveyors

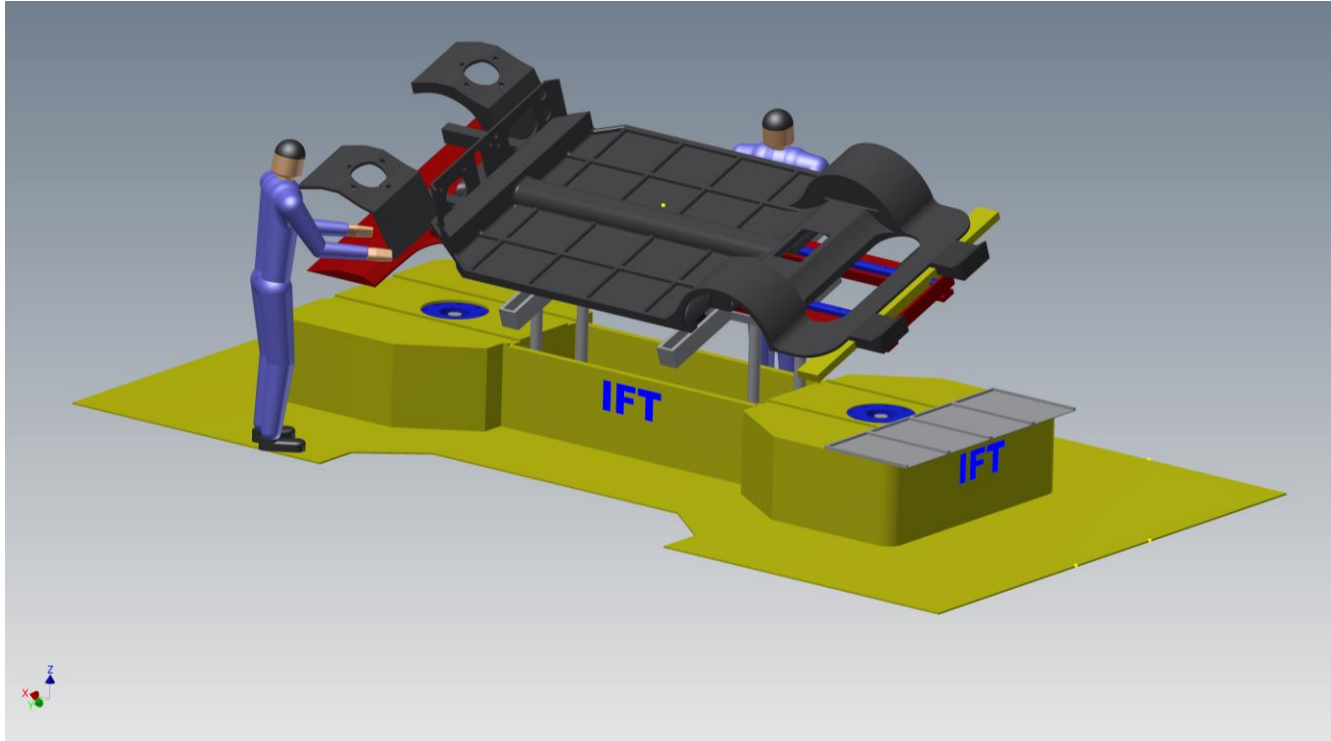





## Material supply for worker platform (AGV)

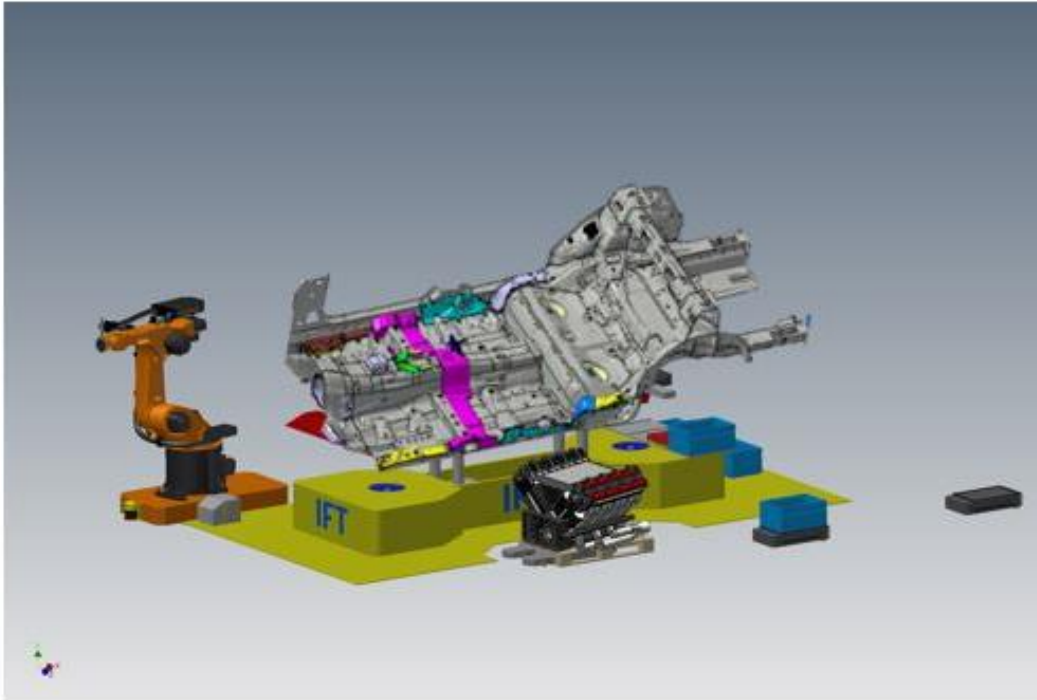

### Connection points:

- Roboter
- Wire mesh boxes
- Universal bins
- Additional manual worker space
- ...

## Three innovative logistics concepts

### Car-set concept:

*Main criteria:*  
High number of variant parts  
at following stations

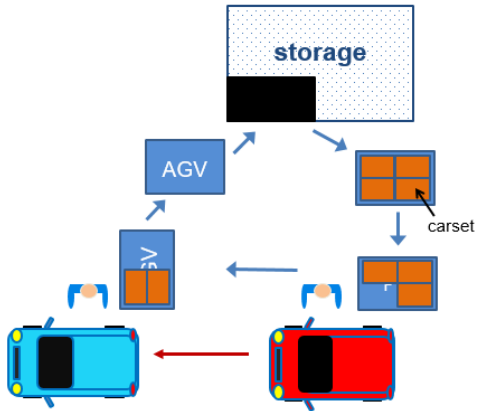

### AGV-concept

*Main criteria:*  
Parts for small  
percentage of cars

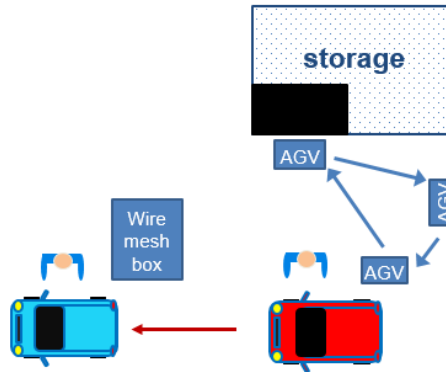

### Rack-concept

*Main criteria:*  
High number of variant  
parts at a certain station

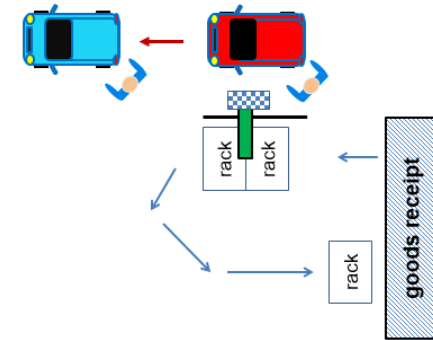



## Rack-concept

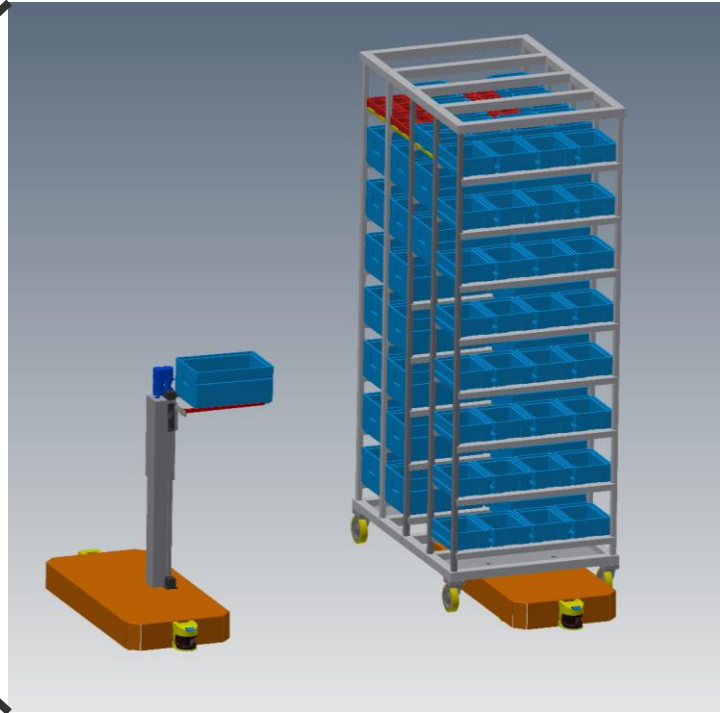
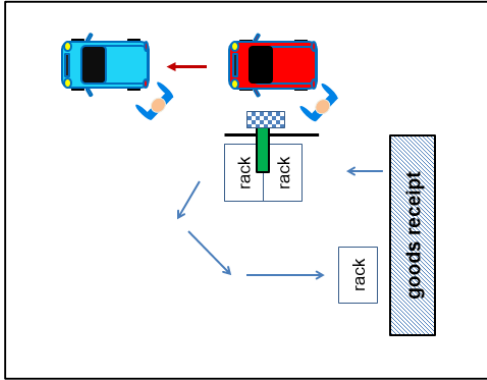



## Simulation rack-concept

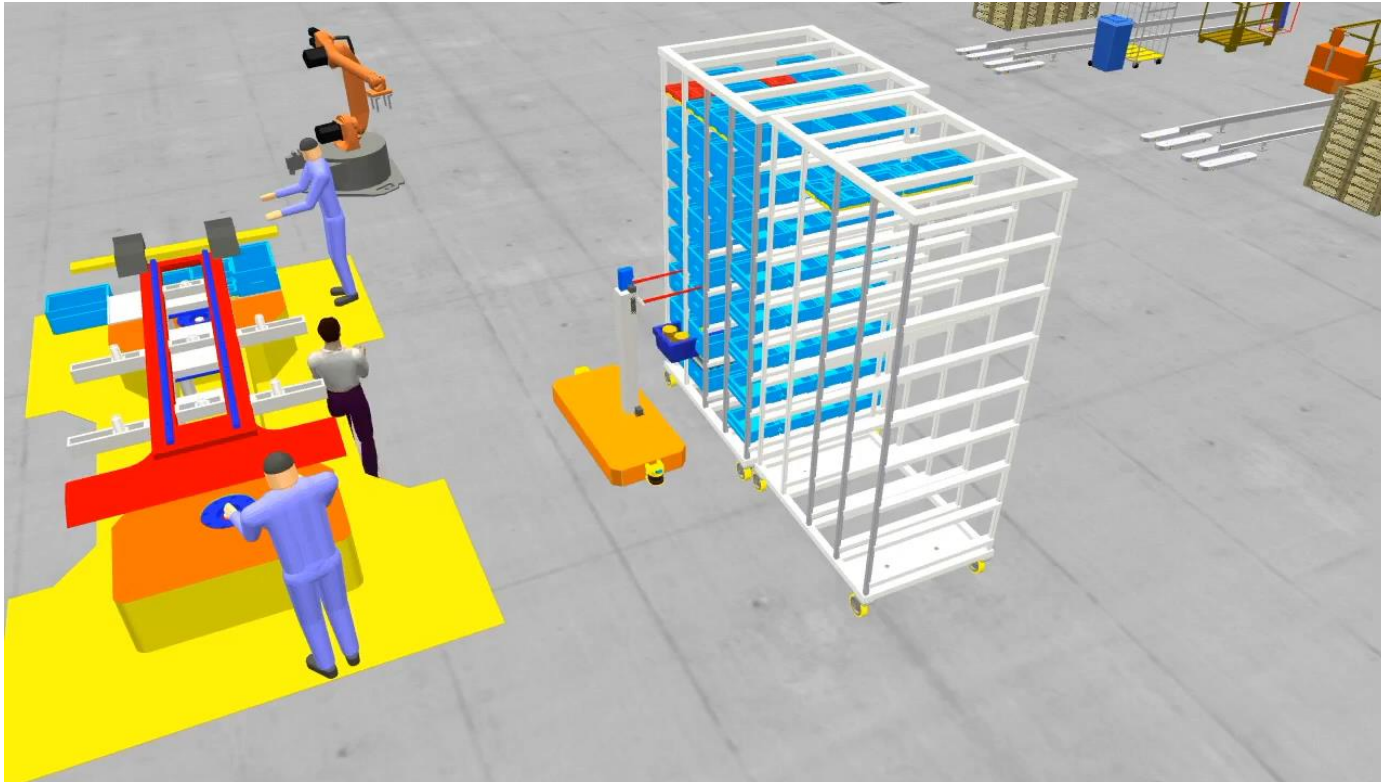



## Prototype rack concept

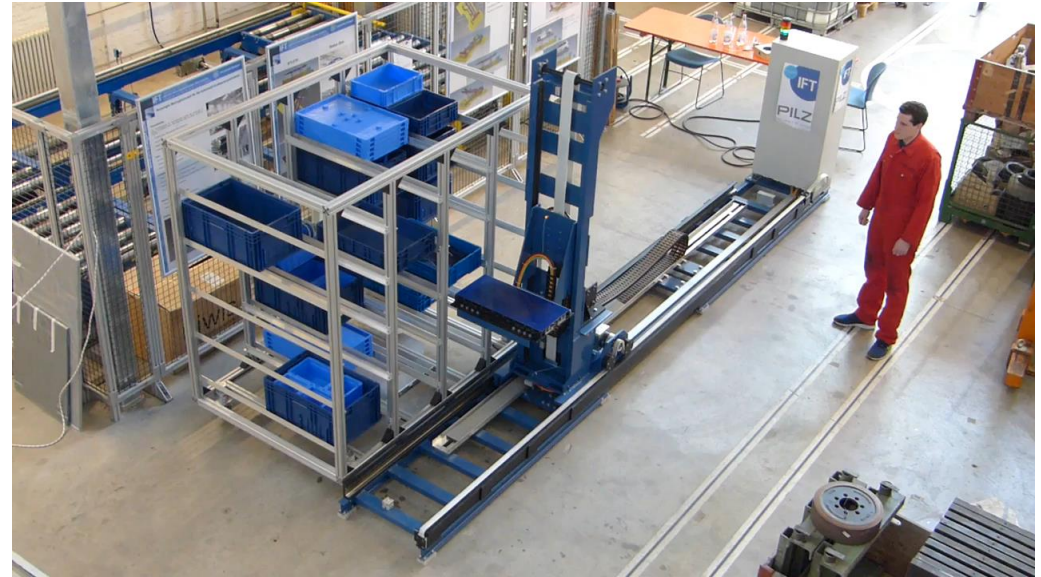



# Linked logistics for the new production

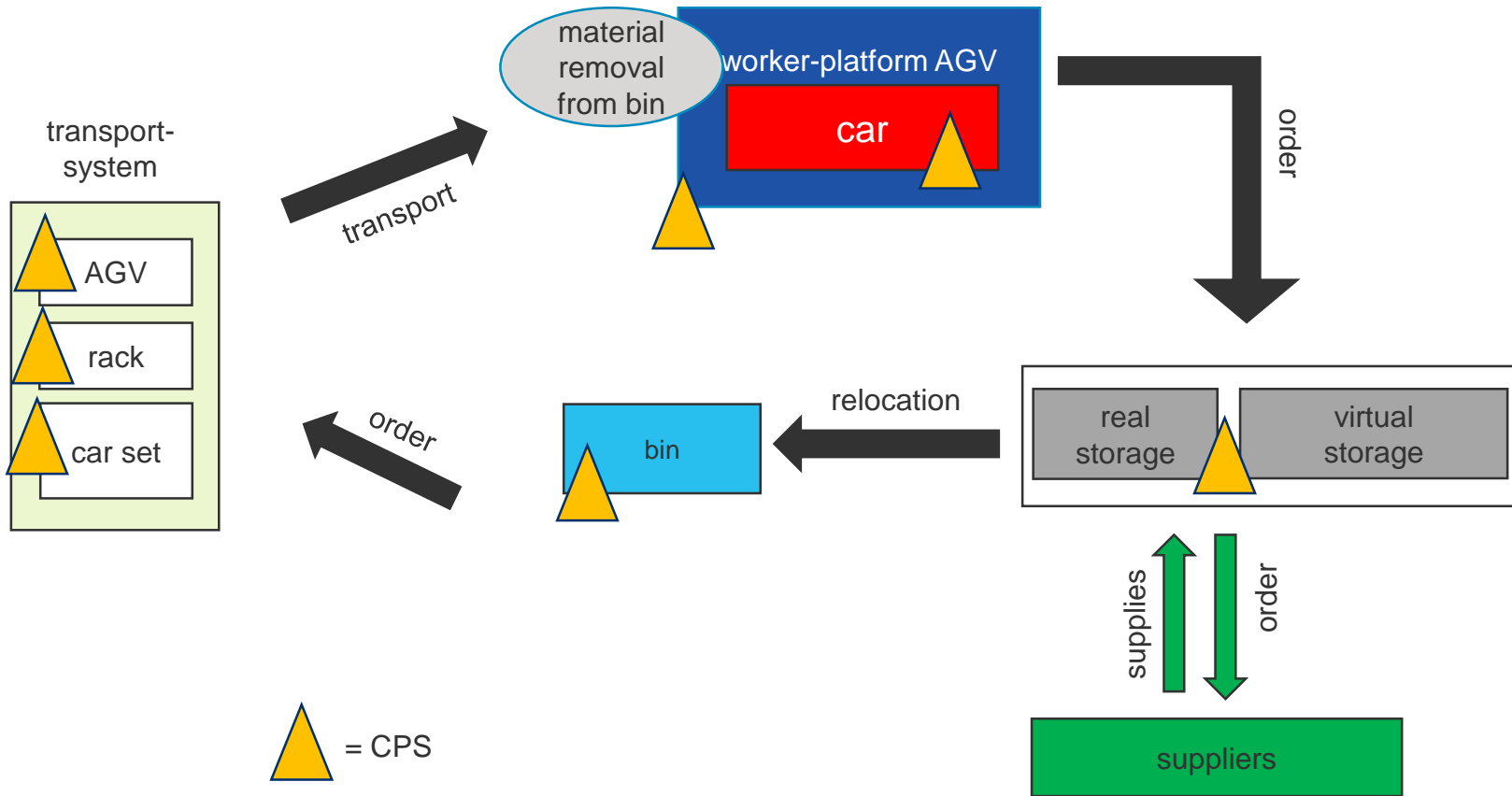



## Linked logistics for the new production

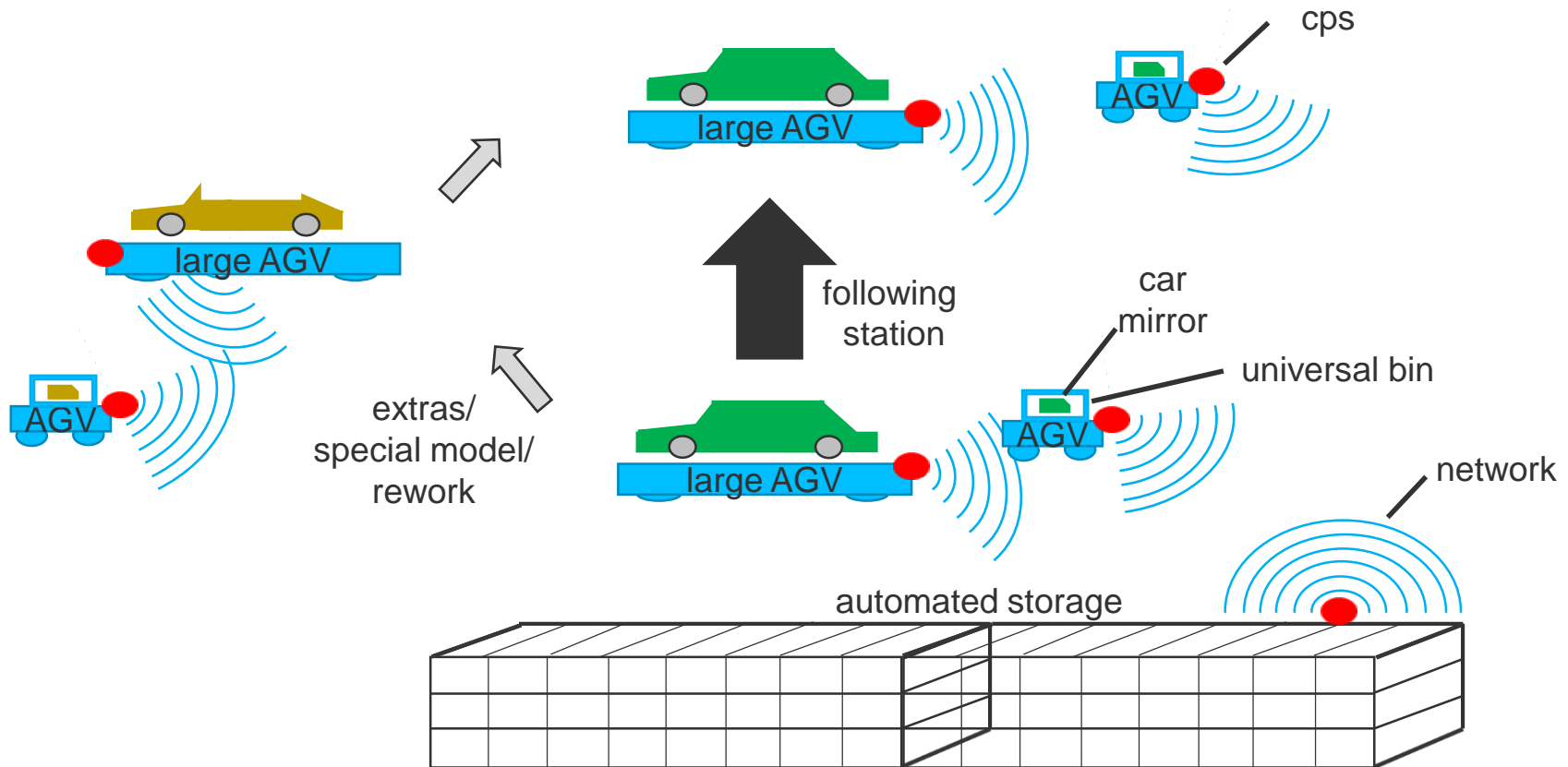



## Summary and Outlook

- Analysis of today's situation
- Development of new logistics concepts
- Concept for connected logistics supporting future of production
- Development of a selection tool for automated rating of logistics concepts





## Thank you



**Dipl.-Wirtsch.-Ing. Julian Popp**  
**academic staff**

E-Mail [Julian.popp@ift.uni-stuttgart.de](mailto:Julian.popp@ift.uni-stuttgart.de)

Telefon +49 (0) 711 685-83672

Fax +49 (0) 711 685-83769

University of Stuttgart  
Holzgartenstraße 15 B  
70174 Stuttgart



**KN  PP**

# Modularization in Warehouses

Roman Schnabl

[roman.schnabl@knapp.com](mailto:roman.schnabl@knapp.com)

# KNAPP AG



# Company

## KEY DATA

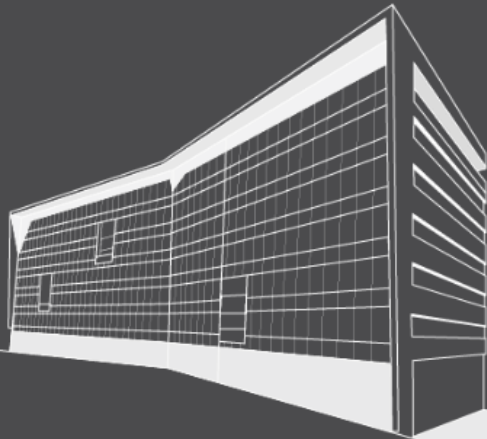

### Headquarter

## KNAPP AG

Hart bei Graz

Founded: 1952  
Company premises: 120,000 m<sup>2</sup>  
Employees at the headquarters: 2,000

Employees worldwide: 3,000  
Locations and offices: 33  
Turnover 15/16: 582 million euros  
Export quota: 98 %

### Production in numbers

Screws/year: 7.8 million  
Shuttles/year: 3,100  
Lifts/year: 210  
Switch cabinets/year: 1,700  
Powder coating/year: 44 t  
Coated surface/year: 181,000 m<sup>2</sup>

### Certifications

Quality management  
ISO 9001

Occupational Health and Safety  
OHSAS 18001

Environmental management  
ISO 14001

# Physical Internet

**Super Grid Logistics**  
Hyperconnected global logistics system

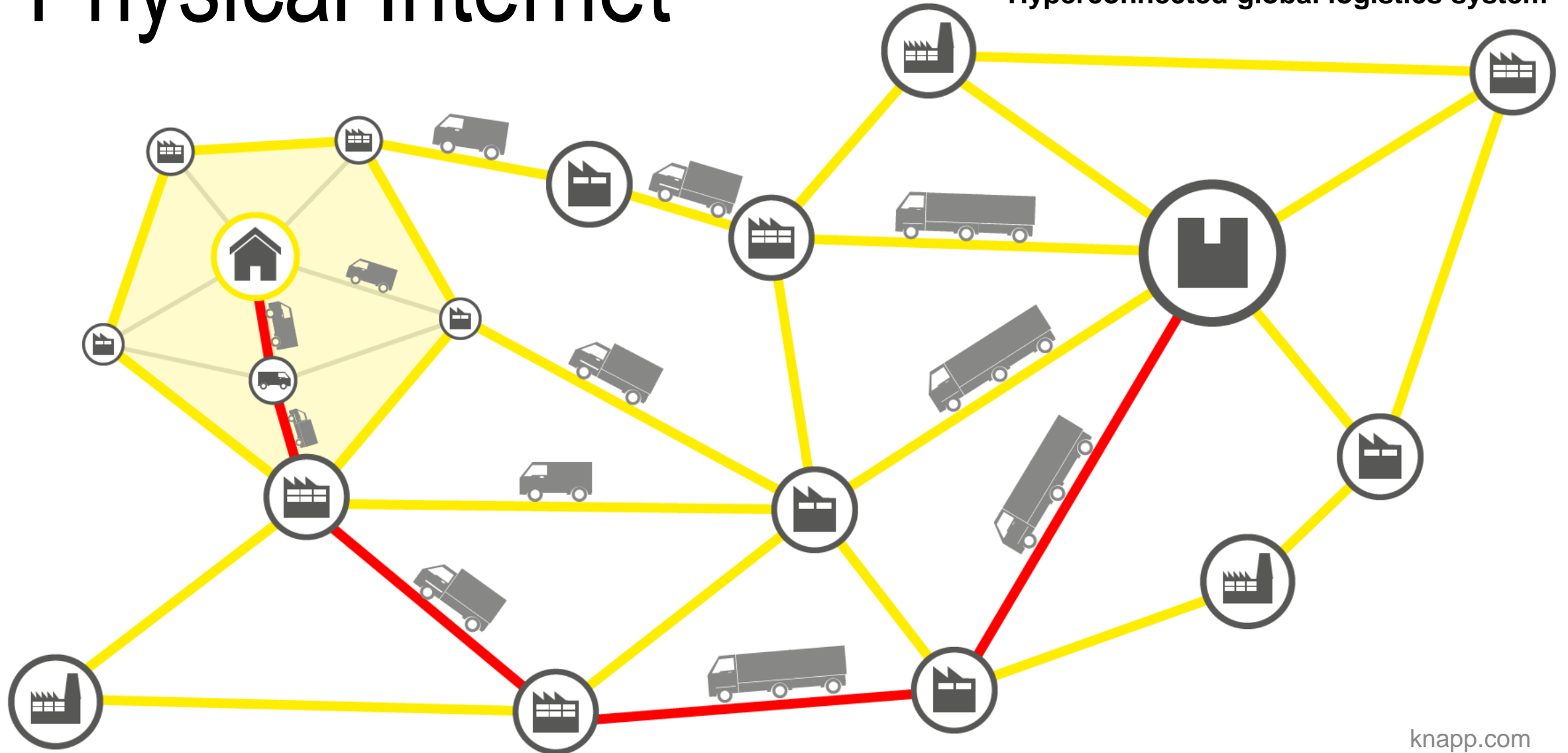

# PI Value Chain

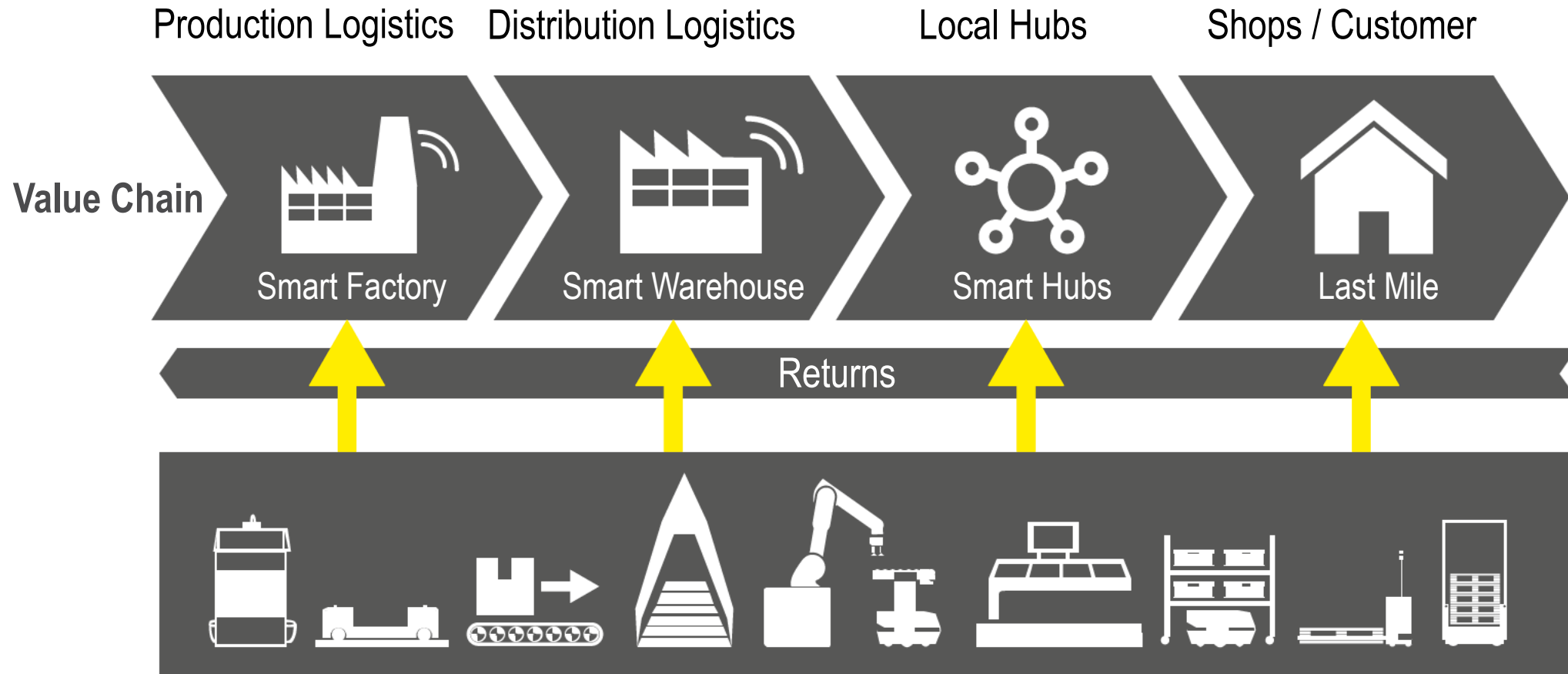

# Industrial Revolutions





# Smart PI Hub (Hyperconnected Mixing Center)

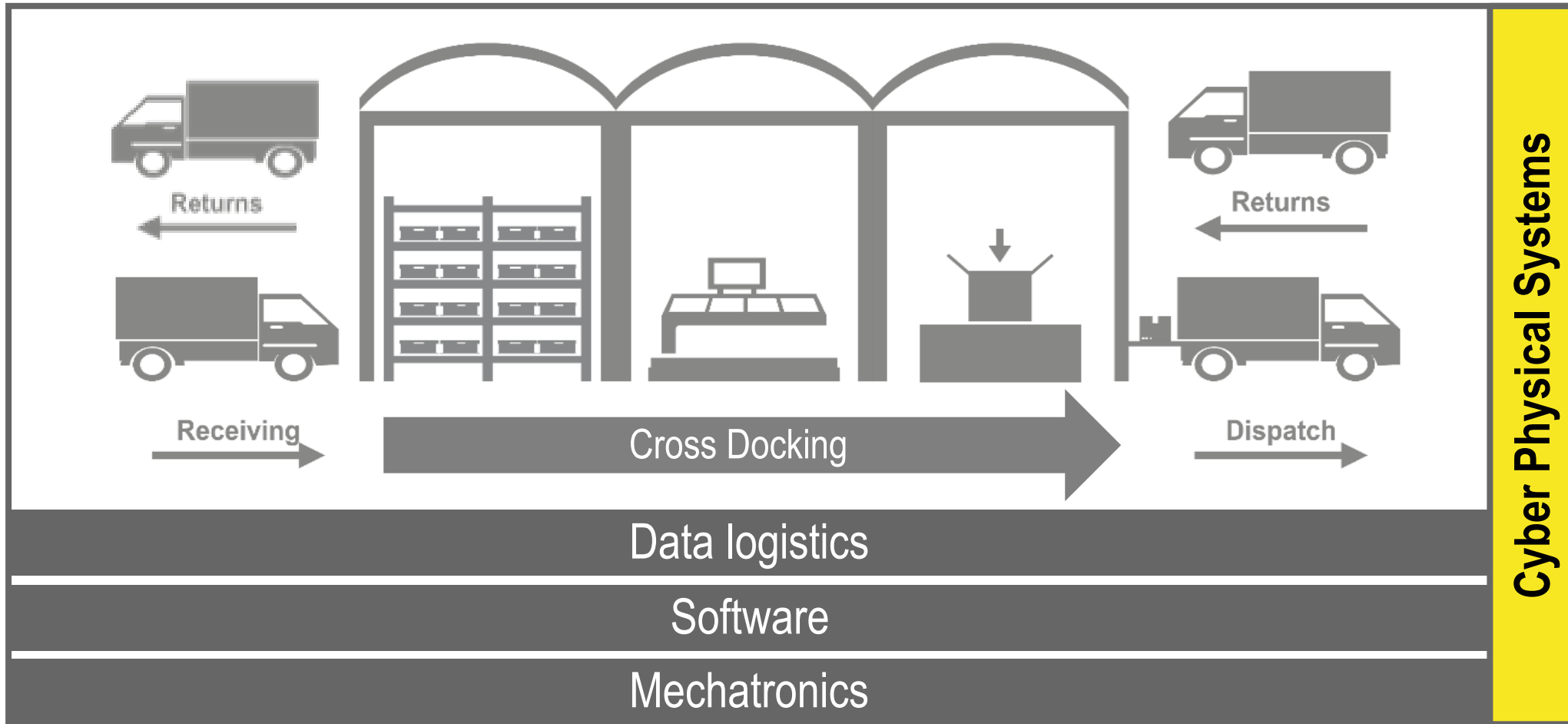

# Cyber Physical Systems

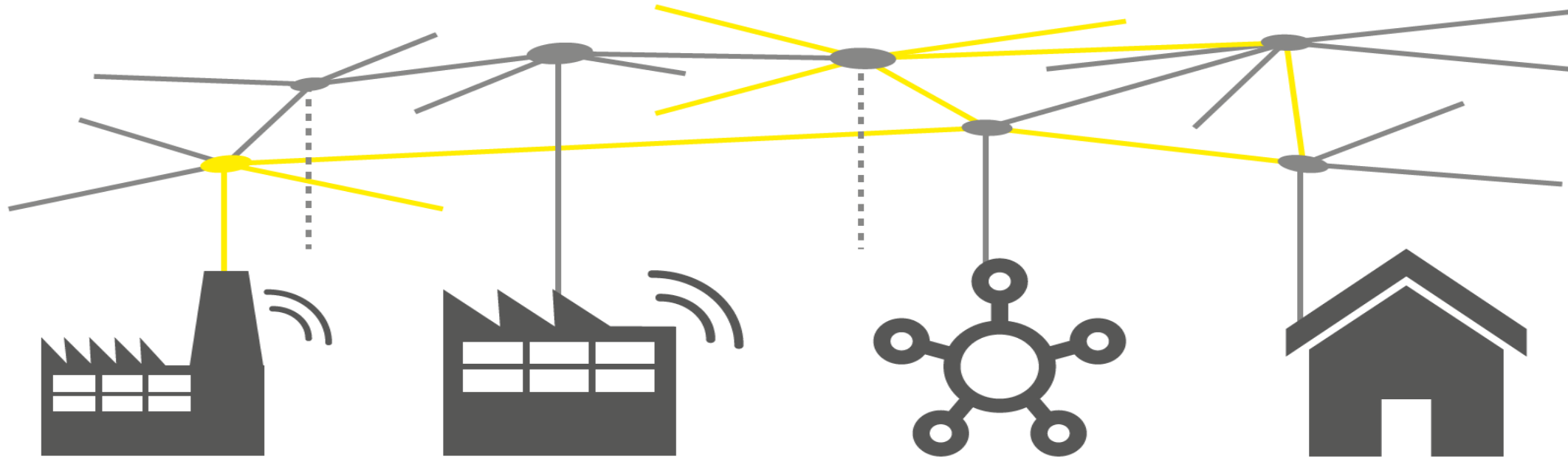

Data logistics

Software

Mechatronics

# Smart PI Hub (Hyperconnected Mixing Center)

- Zero Defect
- Flexibility
- Resource efficiency
- Automation
- Ergonomics
- Business partners integrated into processes

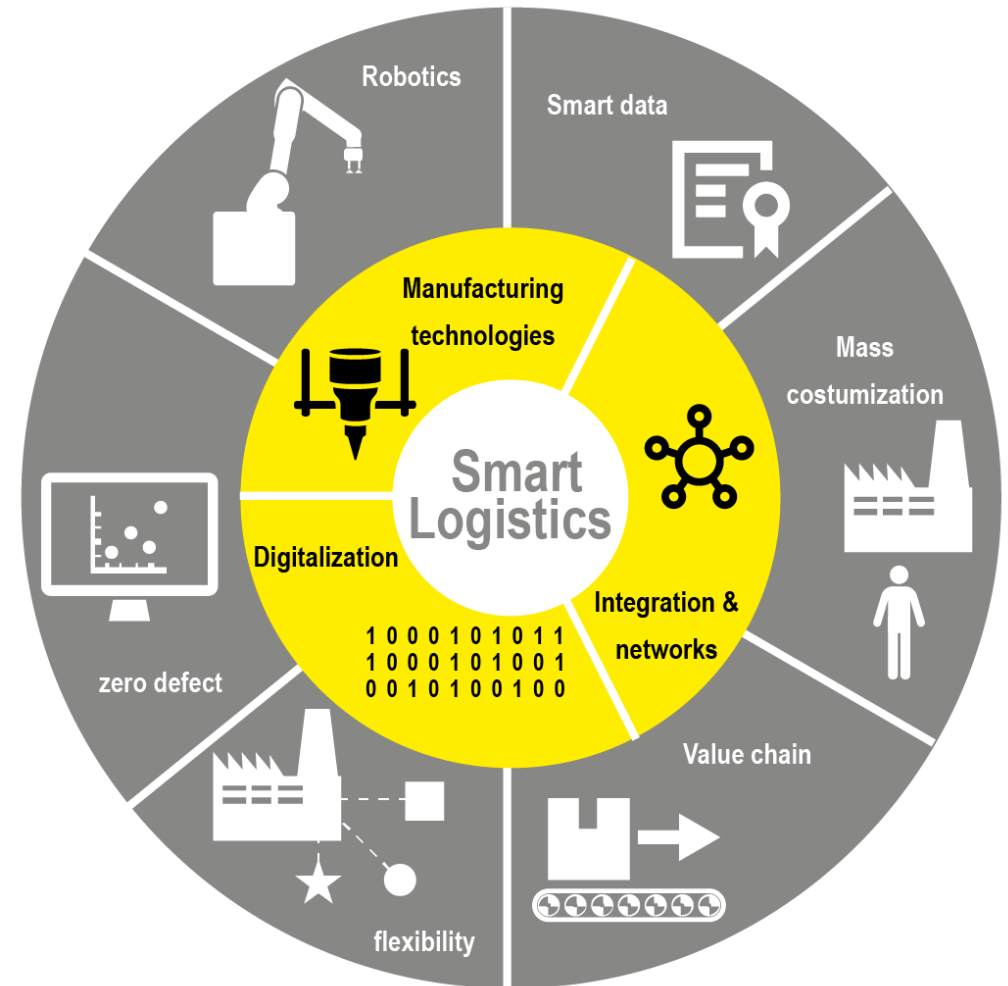

# PI Hub - Modularization

# Example Goods-to-Person Picking

# Goods-to-Person Picking

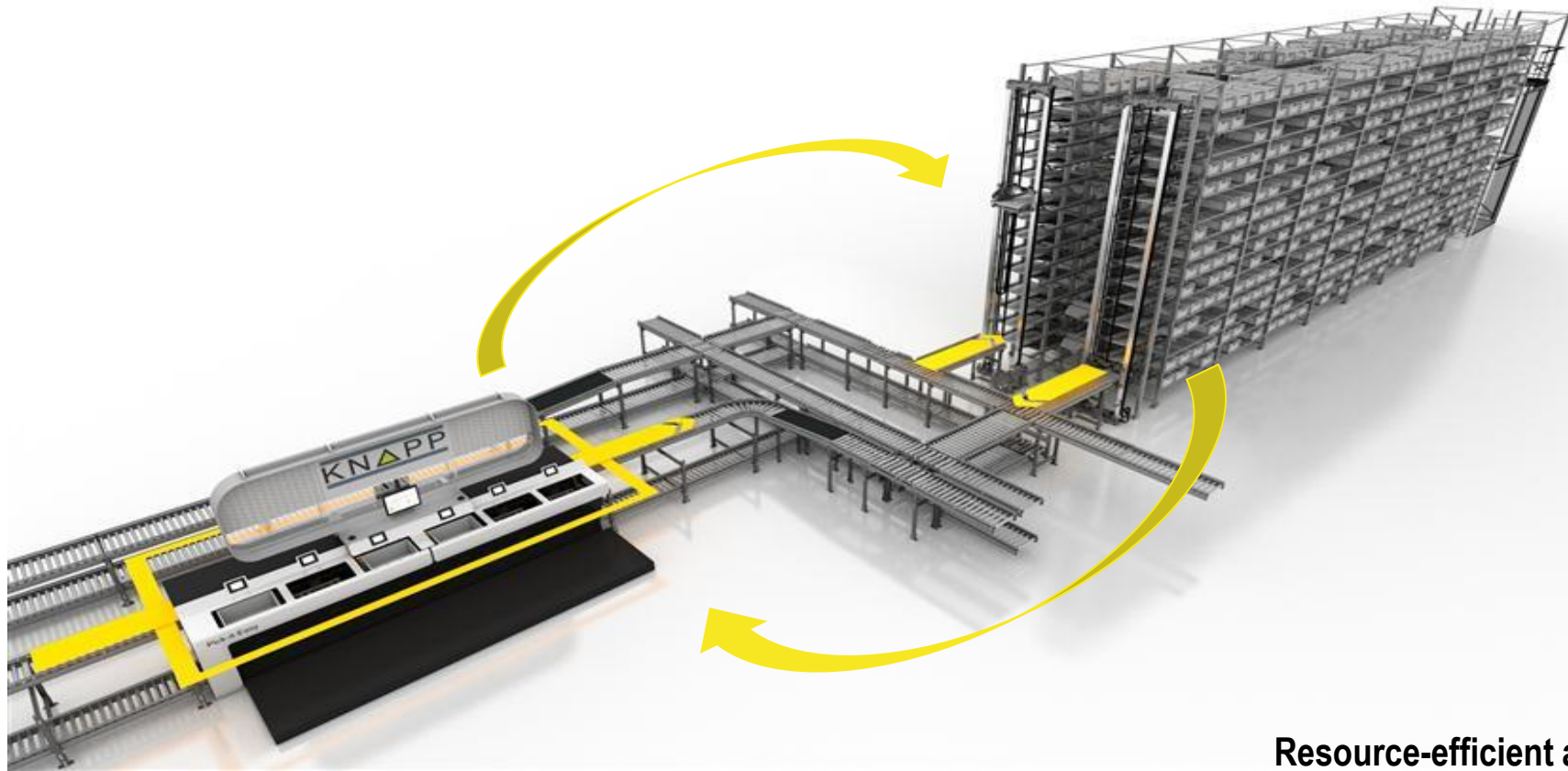

**Resource-efficient and ergonomic**

# Goods-to-Person Picking



Work stations



Conveying system



Storage System

# Goods-to-Person Picking

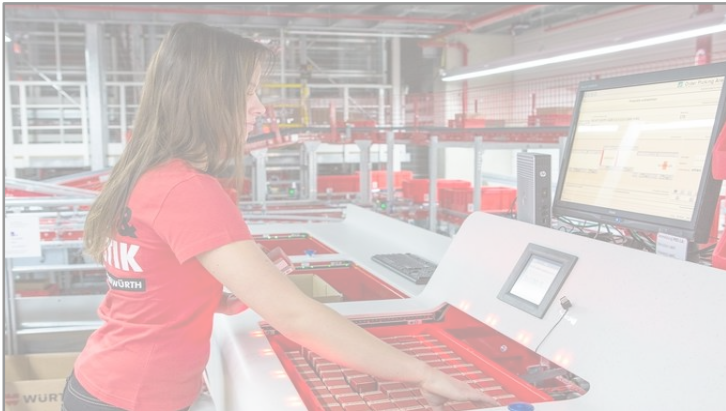

Work stations

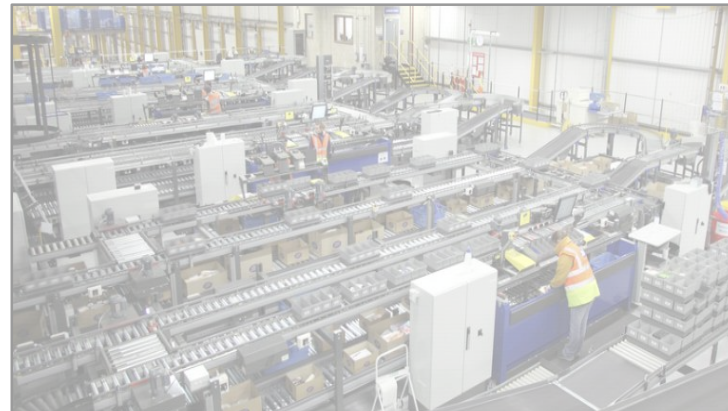

Conveying system



Storage System



# Storage systems

## Selecting a suitable storage system

- Load carriers: pallets, cartons, single item...
- Weight: 1,000kg, 50kg, 10g...
- Spatial requirements (height, floor space)
- Storage and retrieval capacity
- Sequence requests
- Storage Locations
- **Necessary flexibility of the system**



# Smart Shuttles



# Smart Shuttles



# Goods-to-Person Picking

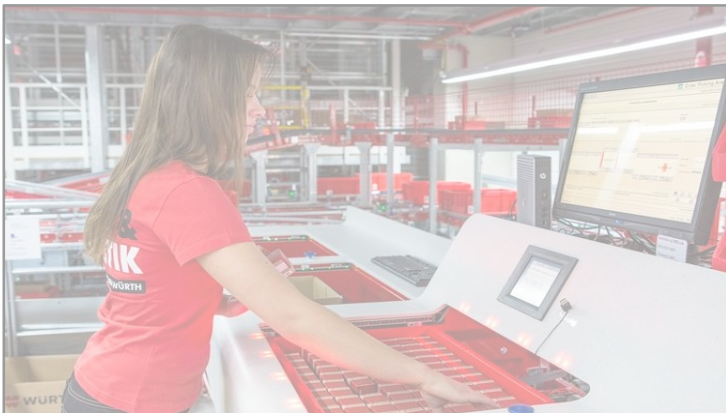

Work stations

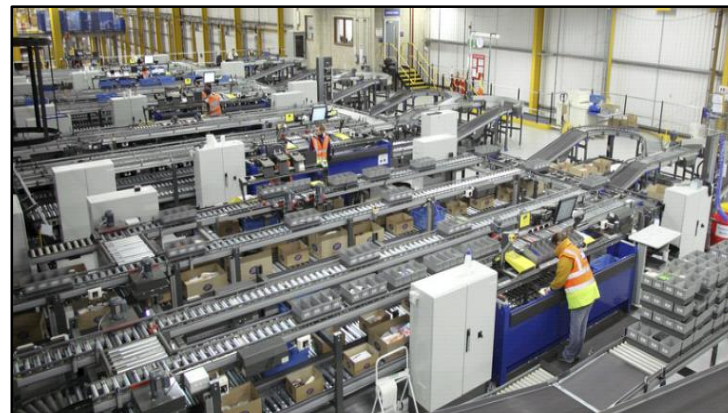

Conveying system



Storage System

# Conveying system

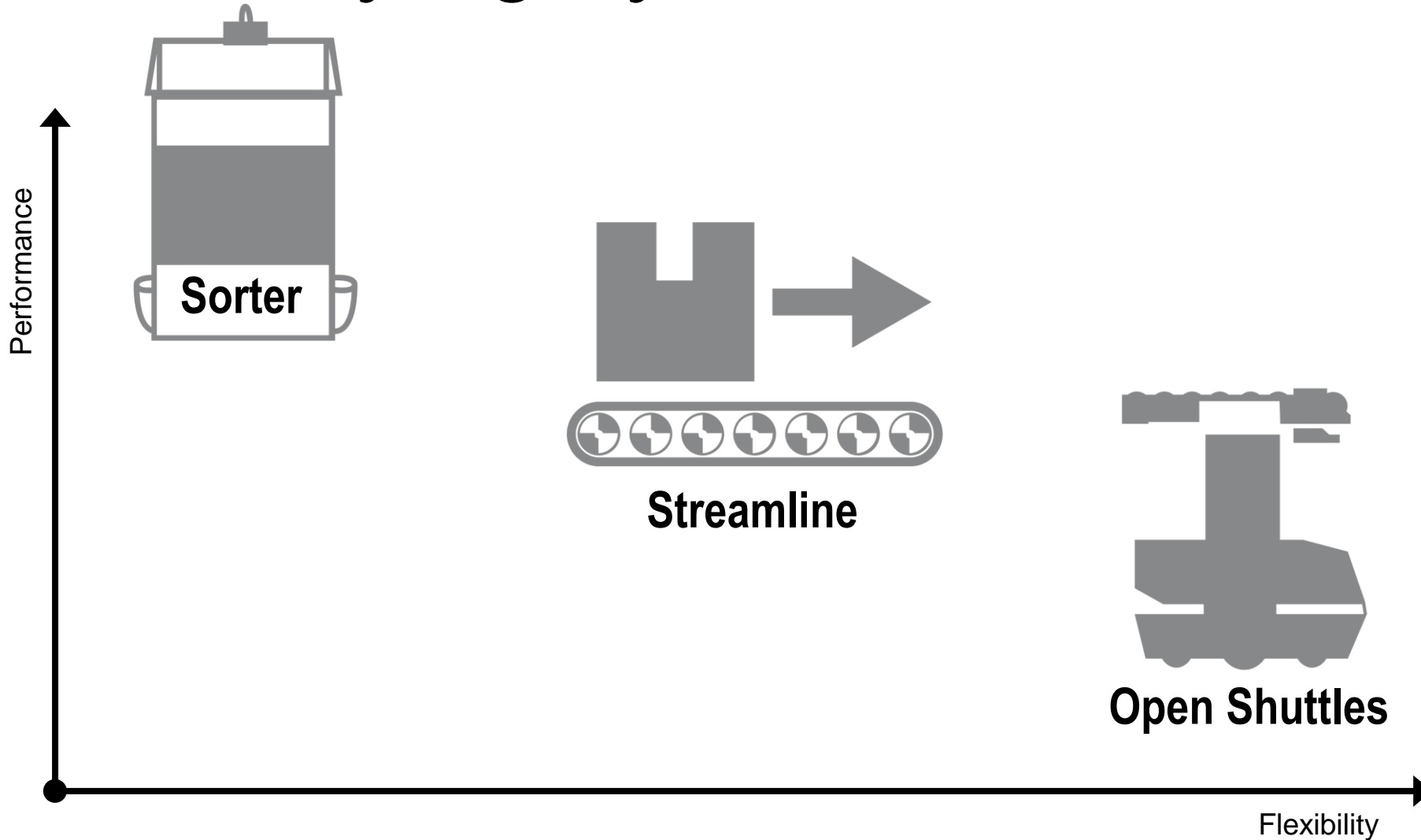

# Pocket System





# Open Shuttles



Open Shuttle



Open Shuttle Fork



Open Shuttle for pallets



# Open Shuttles



# Open Shuttle for pallets



# Goods-to-Person Picking

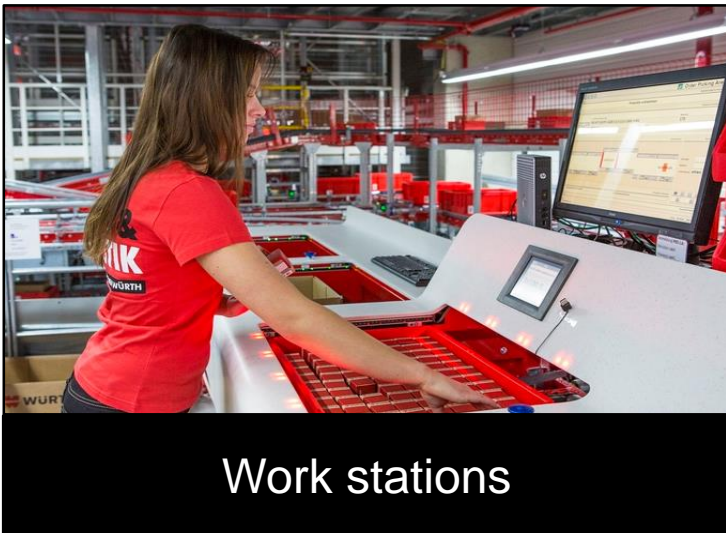

# Pick-it-Easy work stations



# Pick-it-Easy work stations

- Pick-it-Easy series
- Different types of work stations for different requirements and sectors
- Future-oriented design: Ergonomic KiDesign
- Multifunctional; optimized for main tasks
- Benefit: Flexibility, performance, ergonomics, economics and design unified in one concept

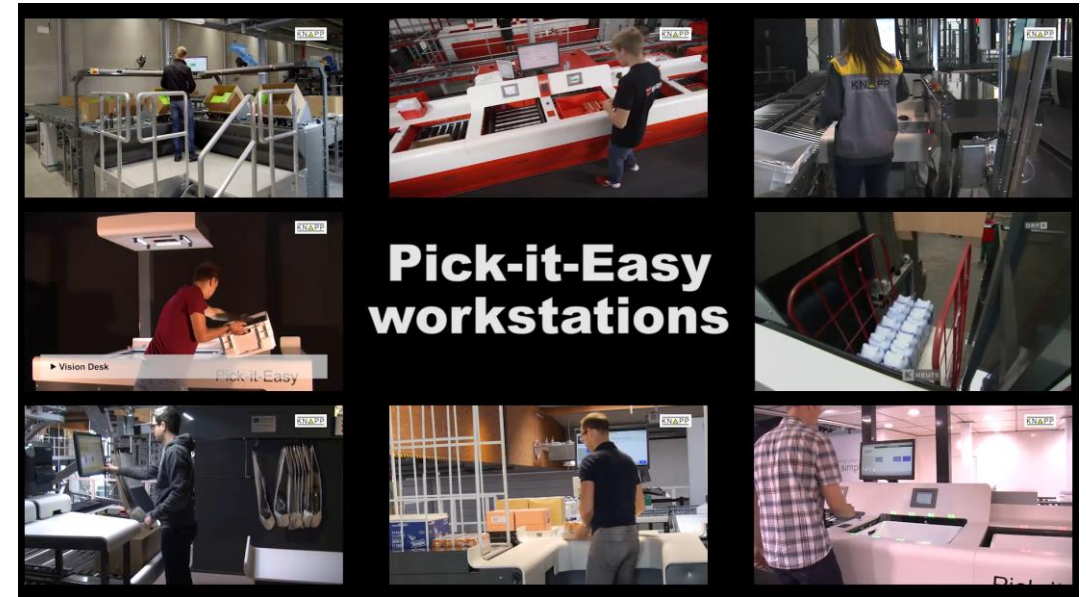

# Pick-it-Easy Robot



# Pick-it-Easy Robot



Fully Automated Bin Picking



References



Dynamics

# Pick-it-Easy Robot

---

PLAY

---

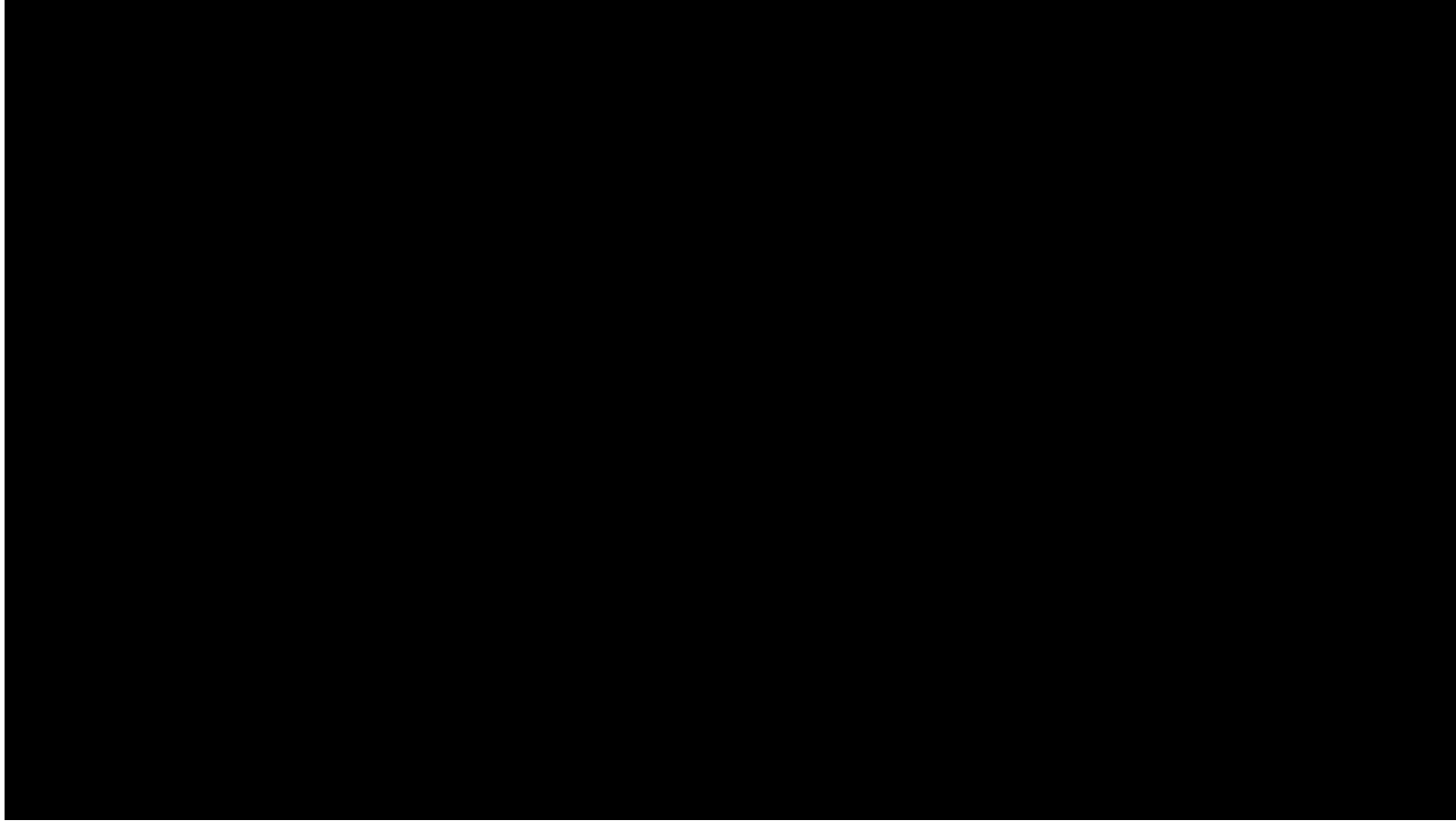



# Goods-to-Person Picking



Work stations

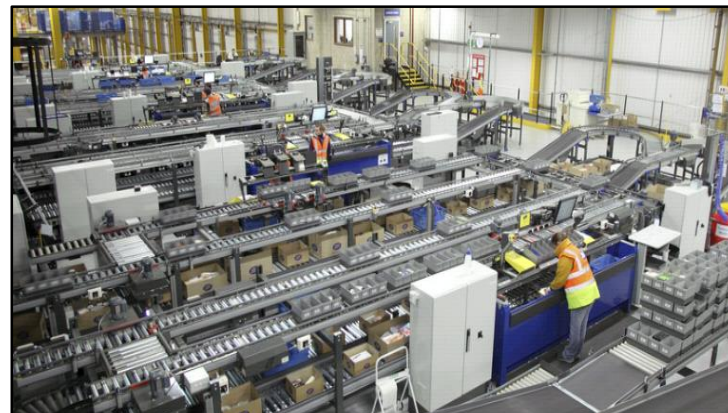

Conveying system



Storage System

# Software



# PI Hub - Smart Logistics Modules

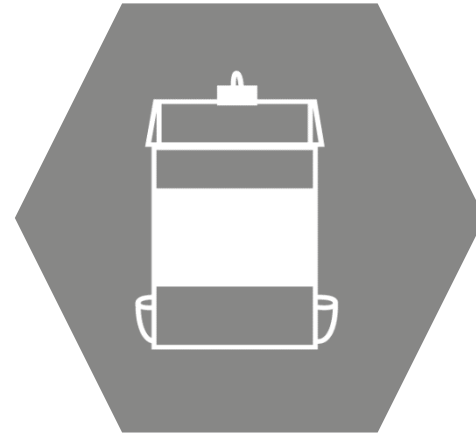
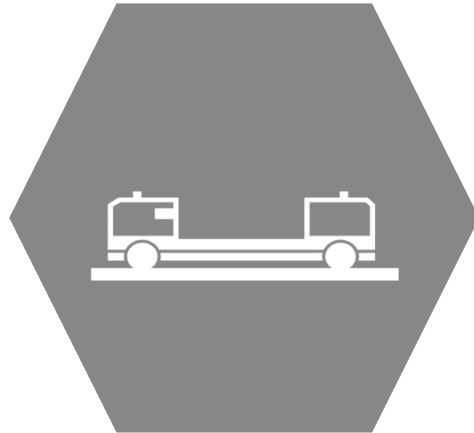
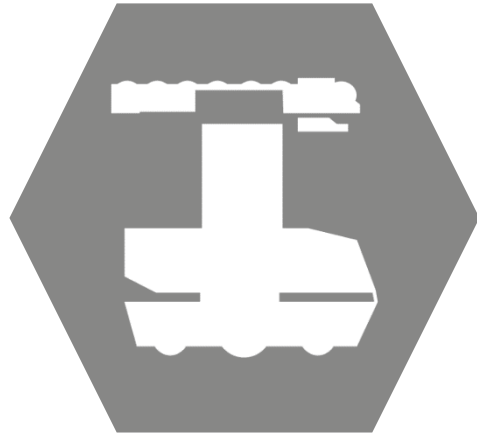
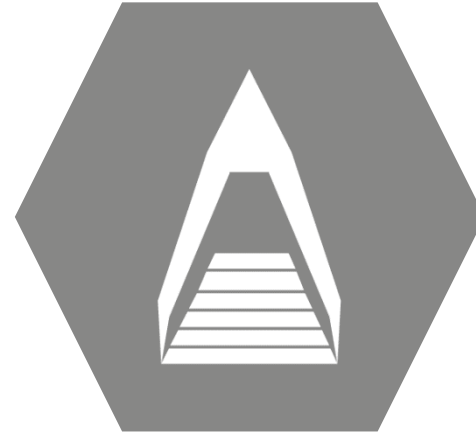
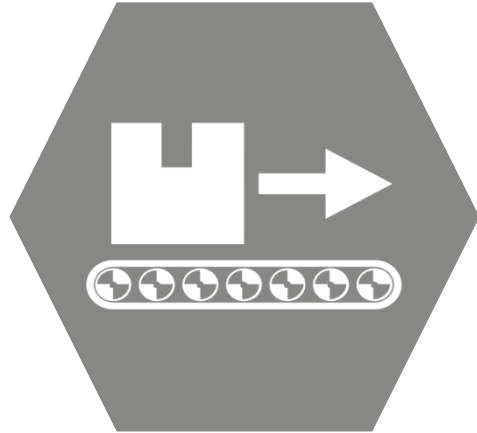

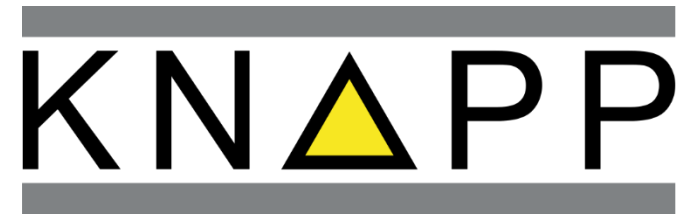
The logo consists of the letters 'KNAPP' in a bold, black, sans-serif font. The letter 'A' is replaced by a yellow triangle with a black outline. The text is centered between two horizontal grey bars.

**KNAPP**

**making complexity simple**

# Questions?



Thank you.

Vielen Dank.

Merci beaucoup.

Muchas gracias.

Mille grazie.

# Short Break

